



Designation: F1349 – 08 (Reapproved 2019)

Standard Test Method for Nonvolatile Ultraviolet (UV) Absorbing Extractables from Microwave Susceptors¹

This standard is issued under the fixed designation F1349; the number immediately following the designation indicates the year of original adoption or, in the case of revision, the year of last revision. A number in parentheses indicates the year of last reapproval. A superscript epsilon (ϵ) indicates an editorial change since the last revision or reapproval.

1. Scope

1.1 This test method covers the determination of nonpolar and relatively polar ultraviolet (UV) absorbing components that may migrate from microwave susceptor packaging into food simulants, such as corn oil and Miglyol 812.

1.2 This test method has been collaboratively studied using bilaminate susceptors constructed of paperboard, adhesive, and a layer of polyethylene terephthalate polymer (PETE) susceptor. Adhesive and PETE related compounds were quantitated using this test method.

1.3 The values stated in SI units are to be regarded as standard. No other units of measurement are included in this standard.

1.4 *This standard does not purport to address all of the safety concerns, if any, associated with its use. It is the responsibility of the user of this standard to establish appropriate safety, health, and environmental practices and determine the applicability of regulatory limitations prior to use.* Specific warning statements are given in 4.3.2.3.

1.5 *This international standard was developed in accordance with internationally recognized principles on standardization established in the Decision on Principles for the Development of International Standards, Guides and Recommendations issued by the World Trade Organization Technical Barriers to Trade (TBT) Committee.*

2. Referenced Documents

2.1 *ASTM Standards:*²

F874 Test Method for Temperature Measurement and Profiling for Microwave Susceptors

F1317 Test Method for Calibration of Microwave Ovens

¹ This test method is under the jurisdiction of ASTM Committee F02 on Primary Barrier Packaging and is the direct responsibility of Subcommittee F02.15 on Chemical/Safety Properties.

Current edition approved March 1, 2019. Published May 2019. Originally approved in 1991. Last previous edition approved in 2014 as F1349 – 08(2014). DOI: 10.1520/F1349-19.

² For referenced ASTM standards, visit the ASTM website, www.astm.org, or contact ASTM Customer Service at service@astm.org. For *Annual Book of ASTM Standards* volume information, refer to the standard's Document Summary page on the ASTM website.

3. Apparatus and Reagents

3.1 *Microwave Oven*, 700 \pm 35 W, calibrated. Refer to Test Method **F1317**.

3.2 *High-Pressure Liquid Chromatograph (HPLC)*, consisting of:

3.2.1 *Pump*, capable of 1.5 mL/min with flow precision \pm 2 %.

3.2.2 *Injector*, loop-type, equipped with 20- μ L loop.

3.2.3 *Guard Column*, C₈, 5 μ m.

3.2.4 *Analytical Column*, C₈, 5 μ m, 250 by 4.6 mm.

3.2.5 *Detector-UV Absorbance*, set for 254 nm. Adjust sensitivity to give a 70 to 100 % of full scale peak for the 5-ppm dimethylterephthalate DMT standard.

3.2.6 *Gradient Program*, 4 to 60 % Mobile Phase B in 8 min; 60 to 70 % B in 9 min; 70 to 100 % B in 7 min; 100 % B for 11 min; 100 to 4 % B in 5 min; 4 % B for minimum of 5 min. Where Mobile Phase A (v/v) is 85 + 15 + 0.25 % water:acetonitrile:acetic acid, and Mobile Phase B (v/v) is 15 + 85 % water:acetonitrile.

3.2.7 *Peak Area Integration System*—Initialize data acquisition or integration system, or both, from 5 to 35 min during the separation.

3.3 *Hexane*, LC/UV grade.

3.4 *Acetonitrile*, LC/UV grade.

3.5 *Corn Oil*—Obtain corn oil that is as pure and fresh as possible to minimize peaks in nonvolatiles extractables chromatogram. Alternatively, Miglyol 812 (a fractionated coconut oil) or synthetic fat simulant HB 307 can be used as a substitute for corn oil.

3.6 *Dimethylacetamide (DMAC)*, LC/UV grade.

3.7 *Conical Bottom Test Tubes*, 50 mL, graduated.

3.8 *Bishydroxyethyleneterephthalate (BHET)*.

3.9 *Diethylterephthalate (DET)*.

3.10 *Dimethylterephthalate (DMT)*.

3.11 *Fluoroptic Thermometry System*.

3.12 *Temperature Probes*, four, high temperature.

3.13 *Glass Beads*, 3 to 4 mm, clean thoroughly by rinsing with methylene chloride followed by soaking for 30 min in acetonitrile. Dry thoroughly before using.

3.14 *Recommended Microwave Nonvolatile Extraction Cell*—Waldorf Polytetrafluoroethylene cell.³ (See Figs. 1-3). This cell must be constructed by a machine shop experienced in working with polytetrafluoroethylene (PTFE). After microwaving oil in the cell, the cell should be rinsed with methylene chloride to remove residual oil and prevent carry-over.

3.15 *Solvent Concentration Apparatus*—Kuderna-Danish evaporative concentrator, rotary evaporator; or Zymark TurboVap at a nitrogen pressure of 30 psi and a water bath temperature of 50°C.

4. Procedure

4.1 Temperature Measurement:

4.1.1 Refer to Test Method F874 to determine the time and water load specifications.

4.2 Sample Preparation and Microwave Heating:

NOTE 1—Always be sure the microwave oven is at ambient temperature before starting any temperature measurement or heating procedure to ensure consistency of output. Cooling of the microwave oven can be

³ The sole source of supply of the apparatus known to the committee at this time is Read Plastics, 12331 Wilkins Ave., Rockville, MD 20852. If you are aware of alternative suppliers, please provide this information to ASTM International Headquarters. Your comments will receive careful consideration at a meeting of the responsible technical committee,¹ which you may attend.

expedited by using ice in beakers or crystallization dishes or by using cold packs such as “blue ice.”

4.2.1 Select a representative piece of the susceptor sample to be tested. If the susceptor is part of a package, trim excess material from around susceptor. Determine the area of the active susceptor material. The susceptor should be cut to fit into a Waldorf PTFE Cell with the screw seal ring firmly seated against the susceptor surface. Use of the Waldorf PTFE cell reduces the risk of spilling hot oil and in addition, gives a reproducible surface area (53.5 cm²) for extraction. Alternatively, cut a 13 by 18-cm rectangular piece of the active susceptor material, form an extraction boat with sides 1.5 cm high (boat configuration = 1.5 by 10 by 15 cm, approximately 150 cm² of surface area). Staple the corners of the boat securely.

4.2.2 Add 53.2 g of Miglyol 812 of corn oil to the Waldorf PTFE Cell. Alternatively, add 22.5 g oil and 75 g of glass beads to the extraction boat.

4.2.3 Measure the mass of the room-temperature distilled water load as determined in 4.1.1 into a 600-mL beaker and add a boiling chip to this beaker.

4.2.4 Place Waldorf PTFE Cell or extraction boat containing the oil in the center of the microwave oven. Always position cell/extraction boat in the same position for subsequent runs.

4.2.5 Insert the temperature sensing probes through pre-formed holes in the walls in Waldorf PTFE Cells (shown in Fig. 1 and in the lower center sketch of Fig. 2), or in the case of the extraction boat, tape the probe to the wall of the oven

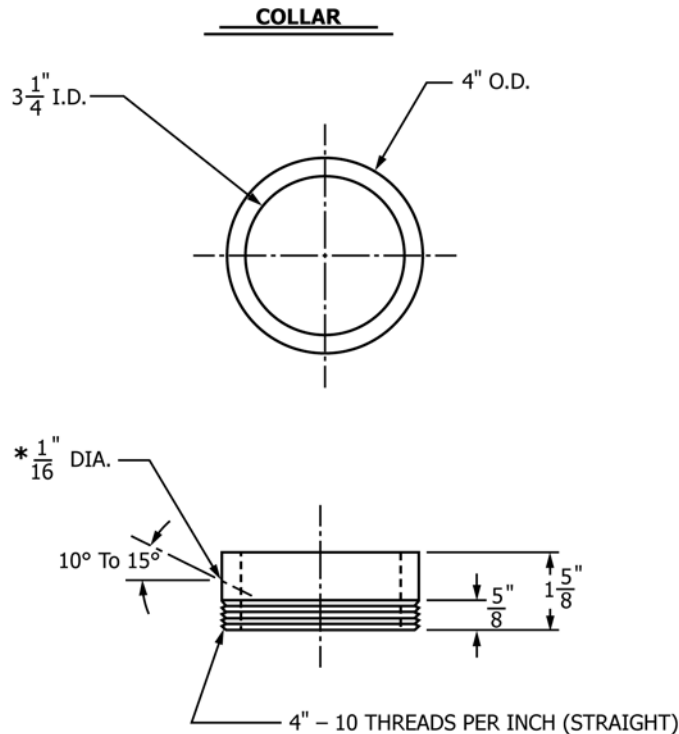

NOTE 1—The 1/16-in. (1.6-mm) diameter hole is for a Luxtron MIW temperature sensing probe. Number of holes and location may vary by application.

FIG. 1 Collar Section of Waldorf Polytetrafluoroethylene Microwave Nonvolatile Extraction Cell